

NightScope™ Infrared Detector

Instant Response (Black)

Model No. NS-340

Delayed Response (Red)

Model No. NS-342

- Reliable & easy **infrared** train detection for model railroads, for all scales
 - Independent of layout lighting: bright, dim, or **no** light
 - No false triggering from other light sources (including infrared)
 - No changes to track wiring, locomotives or rolling stock – no reflectors!
 - Perfect for night operations
- Unlimited model railroad applications
 - Two 200 mA outputs to drive relays, switch motors, or dozens of LEDs
 - Delayed Response model holds detection 2 seconds after train departs
 - Directly drives inputs to model railroad electronics from Digitrax, C/MRI, Logic Rail Technologies, ITT Sound Modules, and others
- Simple installation
 - Self-aligning component installs in the roadbed between the rails
 - Onboard LED lights when train is detected – easy to verify installation
 - Powered directly from railroad electronics or filtered 5-16 VDC supply

The **NightScope™ Infrared Detector** senses reflected infrared light from passing trains, driving target system inputs. This infrared Detector handles many applications in an easy-to-use package.

Before You Install

- Your **NightScope™ Infrared Detector** can be damaged by static electricity. Before removing the Detector from its packaging, discharge static electricity by touching a bare metal surface. Out on the layout, track rail works in a pinch.
- Do not make connections when circuits are powered.
- Insulate all exposed connections, preferably with heat shrink tubing.
- Prevent contact between your Detector and any track wiring.
- Read through the rest of these instructions before beginning.
- Visit www.bouldercreekengineering.com for additional information.

Installation Instructions

(Visit www.bouldercreekengineering.com for step-by-step photos and an alternative installation method without “blind drilling”.)

1. Select the location for your **NightScope™ Infrared Detector**. You will need 5/32” x 3/8” clearance between the rails. For HO scale and larger, the Detector will fit between adjacent ties. For N scale and smaller, you will need to remove ties and drill holes between the rails.
2. Drill one 1/16” pilot hole on your track center line. See Figure 1.

3. Working from below your roadbed, enlarge this pilot hole to 3/8”, by “blind drilling” to within 3/16” of your roadbed/ballast surface. Use a 1/8” bit first, then a 3/8” bit. Use masking tape on the bits to mark desired depth. Work the bit to ream the hole larger than 3/8”.

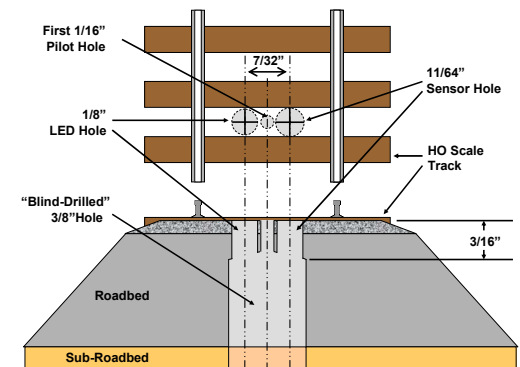

4. From above, drill two more 1/16” pilot holes 7/32” apart on either side of your first pilot hole. A 7/32” drill bit is a handy gauge to mark the distance.

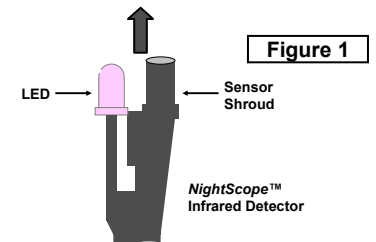

5. Enlarge one pilot hole (LED) to 1/8”.
6. Enlarge the other hole (Sensor) to 11/64”.
7. Clean these surface holes for good Detector performance. Slide the Detector up from below, ensuring the LED and Sensor shroud both penetrate the roadbed and ballast. A drop of cyanoacrylate glue between the Sensor shroud and roadbed will secure the Detector.
8. When ballasting or painting, avoid covering the LED or dropping debris into the Sensor shroud.

Wiring Instructions

The **NightScope™ Infrared Detector's** four 26-gauge color-coded wires are listed in Table 1. These wires may be extended as needed.

Table 1: NightScope™ Infrared Detector Wiring

Wire Color	Name	Function
Red	Power	+5 to +16 Volts DC
Black	Ground	Common with other electronics
Blue	Detect High	Detector output pulled to Power (sources up to 200 mA max.) when train is detected; Otherwise pulled to Ground thru 4.7k ohms
Yellow	Detect Low	Grounded when train is detected (sinks up to 200 mA max.); Otherwise pulled to Power thru 4.7k ohms

Basic connection to other model railroad electronics (target systems) and power supply is shown in Figure 2. Information on connecting to specific target systems can be found at www.bouldercreekengineering.com.

The general sequence for wiring your Detector to a target system is:

1. Connect the BLACK Ground wire to the target system ground and power supply ground. The Detector's outputs are referenced to this point.
2. Connect the RED Power wire to a filtered DC power source supplying +5 to +16 volts. This supply may be shared with the target system – the figure shows a separate supply. The target system power supply should easily handle the Detector's load of 30 - 50 mA (over 5 - 16 V supply range).

Warning: Do not exceed 16 volts DC or apply AC power as this will damage the Detector.

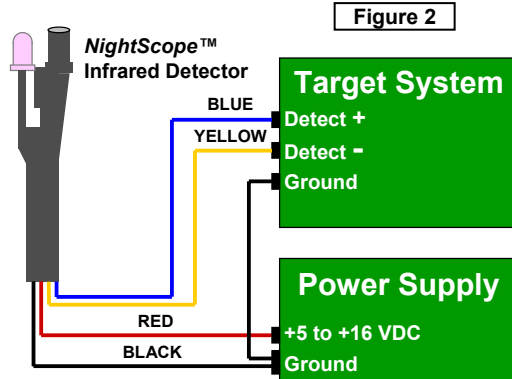

Most target systems require either step 3 or step 4, but not both:

3. Connect the BLUE Detect High output to the “positive sense” input of the target system. This is the target input that expects to see a high DC voltage when a train is detected. Detect High can supply up to 200 mA.
4. Connect the YELLOW Detect Low output to the “negative sense” input of the target system – the input that expects to see a near-ground voltage when a train is detected. Detect Low can sink up to 200 mA.

Warning: Do not exceed the maximum current ratings specified above for Detect High or Detect Low as this will damage the Detector.

Support & Service

If you have problems with your **NightScope™ Infrared Detector**, please consult our website www.bouldercreekengineering.com. If you need additional help, please contact us at support@bouldercreekengineering.com.

Your Detector can be repaired with a reasonable charge for parts and labor. Please contact support@bouldercreekengineering.com for a cost estimate on non-warranty repairs before sending Detectors to us.

Limited Warranty

Boulder Creek Engineering, LLC warrants its products to be free of defects in materials and workmanship for a period of **one (1) year** from the purchase date. Defective product received by Boulder Creek Engineering during the warranty period will be repaired or replaced at our option. You must pay shipping to and from Boulder Creek Engineering.

This warranty does not cover damage resulting from negligent installation, improper operation, or unauthorized repair or modification. Removal of the heat shrink voids this warranty. Boulder Creek Engineering makes no other warranty of any kind, expressed or implied. In no event shall Boulder Creek Engineering be liable for incidental or consequential damages.

For warranty service, please contact Boulder Creek Engineering for a Return Merchandise Authorization (RMA) number. Product must be shipped to Boulder Creek Engineering with dated proof of purchase (your receipt).



2525 Arapahoe Avenue
Suite E4-605
Boulder, CO 80302

support@bouldercreekengineering.com

(303) 443-5784