

WeighStation™ Track Scale

Digital Display

Model No. WS-22

-2-

Prototypical Track Scale for model railroad operations

- Displayed weight (lbs.) varies from car to car within user-defined range
- 3 selectable ranges for car variety or Loads/Empties/Scale Test
- Realistic modern display action as cars move on and off the scale
- Optional “typewriter” sound and display mode for vintage experience
- Optional LED and bell alert when weighing is complete
- Optional red & green LED “traffic light” to guide train crews
- Data Link sends weight to printers, C/MRI, computers, other electronics
- **NightScope™ Infrared Detector** for day or night operation
- Supports both Weigh In Motion and Static weighing operation

Simple installation

- Gantlet or single track arrangement
- Faceplate/Circuit Assembly with Fascia Template for clean installation
- Screw terminals for all circuit board connections
- Power Supply: DC (9-12 V) or AC (7-9 V), 250 mA minimum **required**

Parts List

- **WeighStation™ Track Scale** Faceplate/Circuit Assembly
- **NightScope™ Infrared Detector**
- Piezoelectric Bell Assembly
- Fascia Template

Notice: This product simulates weighing for model railroad operations, and does not provide the true weight of rail cars.

Before You Install

- Your **WeighStation™ Track Scale** can be damaged by static electricity. Before removing the circuit board from its packaging, discharge static electricity by touching a bare metal surface.
- Do not make connections when circuits are powered.
- Insulate all exposed connections, preferably with heat shrink tubing.
- Prevent contact between your Track Scale and track wiring.
- Read through the rest of these instructions before beginning.
- Visit www.bouldercreekengineering.com for additional information.

Gantlet or Single Track?

Prototype railroads have historically used a gantlet track arrangement to keep heavy locomotives off delicate track scales. See Figure 1. Today, railroads install track scales directly on single track with electronic load cells robust enough to support slow moving locomotives. Even so, gantlet track scales are still widely used.

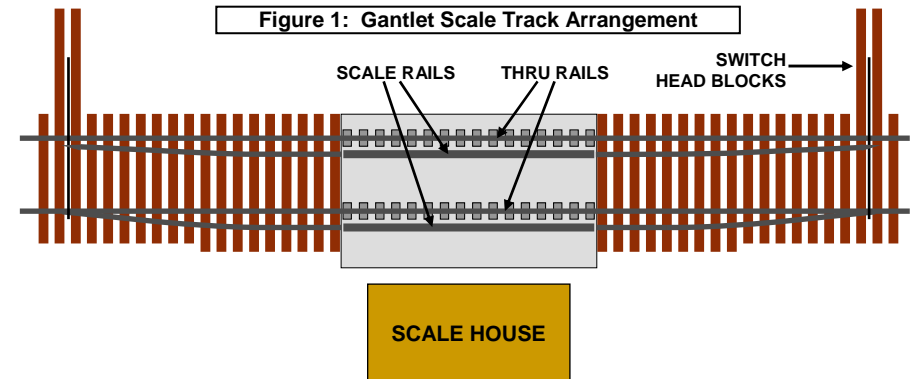

The **WeighStation™ Track Scale** will support either single track or gantlet track installations. If you install on single track, use the WEIGH switch on the Track Scale faceplate to turn the scale on and off. See Figure 2. If you install a gantlet track, simply leave the WEIGH switch on.

Walthers offers a structure kit (933-3199) for gantlet scale tracks, and the September 2002 and April 2009 Model Railroader magazines feature gantlet track scale projects.

Figure 2: Faceplate Controls

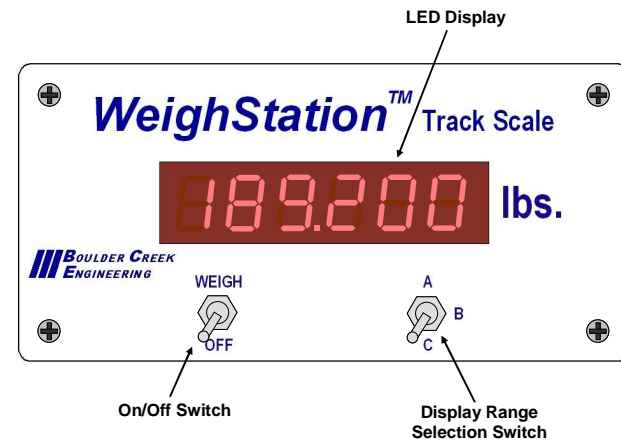

Installation Instructions

(Visit www.bouldercreekengineering.com for step-by-step photos.)

1. Select the location for your **WeighStation™ Track Scale**. You will need a 3" by 6" space on your fascia for the Track Scale Faceplate/Circuit Assembly, with at least 2" clearance behind it.
2. Install the **NightScope™ Infrared Train Detector** at the mid point of the scale track following its packaged instructions. Use the physical alignment described in either a or b below:

- a. If you are installing as a single track, install the Detector between the rails as in the Detector instructions.
- b. If you are installing as an HO gantlet track, install the Detector as shown in Figure 3, following the steps in the Detector instructions.

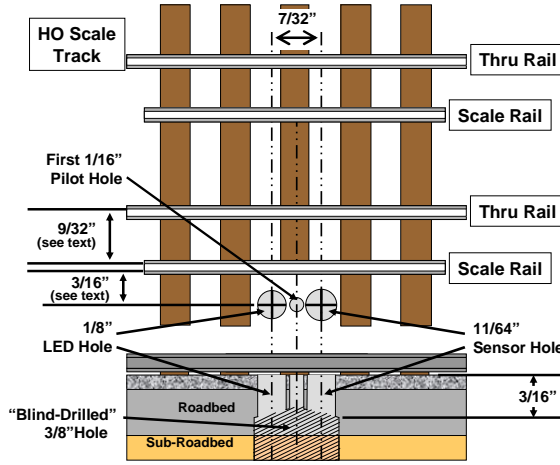

Figure 3: Detector Installation for Gantlet Track

- The Scale Rail should be a scale 24" from the Thru Rail. Thus in HO Scale the rails are 9/32" apart as shown, and in N Scale the rails will be 5/32" apart. While 3" wider than the prototype, 24" is needed between the rails due to the variation in model rail car widths. The Detector hole centers are 3/16" from the outside edge of the outside Scale Rail in HO, 3/32" for N Scale.
3. Use the included Fascia Template to mark the screw and display holes on your fascia. The template shows clearance holes for No. 4 machine screws – smaller holes (or none at all) are needed for wood screws.
 4. Cut out the display hole; drill the screw holes if needed.
 5. Mount the Track Scale Faceplate/Circuit Assembly to your fascia with No. 4 pan-head screws (not included).
 6. Mount the optional Piezoelectric Bell Assembly in or near your scale house, or on your fascia. Drill two 3/32" holes 3/8" apart at your chosen location to thread the wires. If needed, a drop of ACC on each of the bottom mounting pins will hold it in place.

Wiring Instructions

Figure 4 shows how to wire your **WeighStation™ Track Scale**, along with key features on the circuit board.

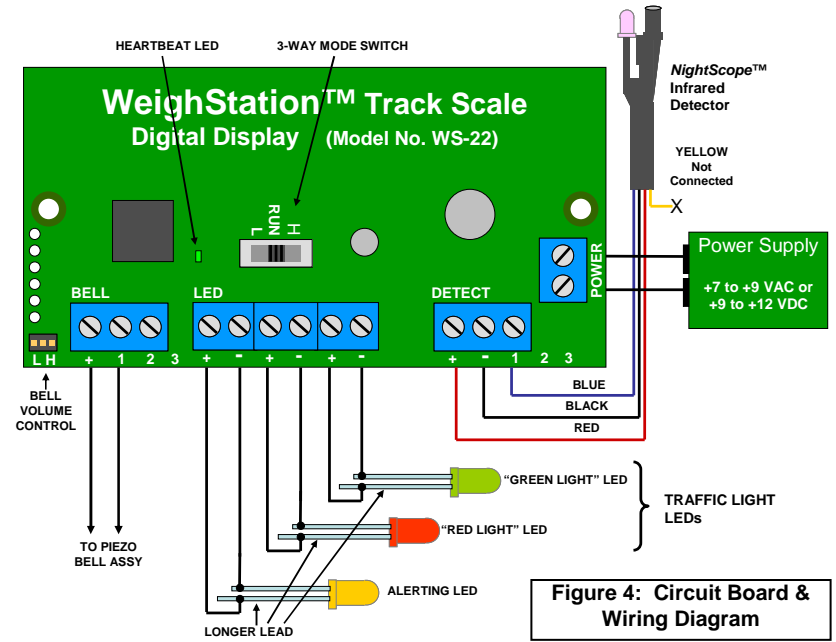

Figure 4: Circuit Board & Wiring Diagram

1. Connect two wires from your power supply to the Track Scale power terminals as shown in Figure 4. Polarity does not matter. The power supply must be 7 to 9 Volts AC or 9 to 12 Volts DC, with 250 mA capacity. Radio Shack sells an AC adapter (#273-314) that works well.
Warning: Do not exceed 9 Volts AC or 12 Volts DC as this will damage the circuit board.
2. Connect the RED, BLACK and BLUE wires from the **NightScope™ Infrared Train Detector** as shown in Figure 4. The YELLOW wire is not used – trim it and insulate the end.
3. If you are using the Piezoelectric Bell Assembly, connect it between (+) and (1) terminals as shown in Figure 4. Polarity does not matter.
4. You can directly wire an Alerting LED as in Figure 4. Install the LED on or near your Scale House. Or you can install the red and green "traffic light" LEDs as shown. (LEDs are not included.) LEDs are polarity sensitive – connect the long and short leads as shown. The Track Scale circuit board sources 20 mA at 2 Volts for each LED.
Warning: Do not connect an LED or other circuitry exceeding 20 mA at 2 Volts as this will damage the circuit board.

Operation

Upon power up, the **WeighStation™ Track Scale** flashes the low and high Display Range values for the currently selected range. This range may be adjusted as described in the **Setting Display Ranges** section.

The Track Scale Circuit Board has a green “Heartbeat LED” (see Figure 4) that blinks every second while the Track Scale is waiting for a car. It is steadily on while the Track Scale is generating a car weight, or while setting the Display Range.

For single track installations, the On/Off Switch (see Figure 2) initiates the weighing operation. It should be set to “WEIGH” when weighing is desired, and set to “OFF” when it is not. For gantlet track installations, the On/Off Switch should always be set to “WEIGH”.

Before weighing, set the Display Range Selection Switch to the desired range. See the **Setting Display Ranges** section for description of the factory programmed ranges and how to modify them for your operation.

With the 3-Way Mode Switch in the **RUN** position, the Track Scale performs as follows:

1. Scale active but unoccupied. [Optional “traffic light” LEDs are Green.]
2. When a rail car is spotted on the active scale track, the scale waits a moment before beginning to display. [Green]
3. The weight displayed ramps up authentically to a random weight in pounds (lbs) within the selected Display Range. (If the Typewriter Display option is selected, each digit is displayed one at a time, accompanied by a simulated typewriter keystroke sound.) [Red]
4. The Digital Display occasionally shows realistic slight instability. [Red]
5. Shortly after weight reading stabilizes, the Alerting LED lights and the Piezo Bell sounds to alert the train crew to spot the next car. [Green]
6. As soon as the car is removed, weight displayed ramps down. (If the Typewriter Display option is selected, the weight reading scrolls up and away, scrolling in a “0” from below.) [Green]
7. The Data Link sends a W Packet (see **Report Data Link**). [Green]
8. Cycle 2 – 7 repeats with spotting of next rail car.

The Track Scale responds quickly enough at prototypical speeds (less than 5 miles per hour) for “weigh in motion” operations.

Visit www.bouldercreekengineering.com for operating ideas, paper forms, and other materials for integrating rail car weighing into your operations.

Defining a Display Range

Your **WeighStation™ Track Scale** has three Display Ranges, selected by setting the Display Range Selection Switch on the Faceplate (see Figure 2). The Track Scale is factory programmed with:

- A) Loads – “normal” operating mode, displaying 50,000 – 200,000 lbs.
- B) Empties – typical weight of empty rail cars, 40,000 – 50,000 lbs.
- C) Test – displays slightly varying weight of a scale test car: 80,000 lbs.

You may use these Display Ranges or you may modify them to create Display Range settings to fit your operations.

For example, you may want to have: A) a fairly tight range for weighing single commodity cars of similar capacities (like coal hoppers), B) a second wider range for all other loaded cars, and C) a single-value range (like the factory setting) for your scale test car.

Choose weight limits for a Display Range based on the data stenciled on the cars you intend to weigh with that Display Range. Using coal hopper cars as an example, find the hopper with the smallest **load limit**. Add the **light weight** to the **load limit** – this will be the absolute maximum **gross weight** for your coal hopper cars. If your smallest hopper has a load limit of 125,200 lbs. and a light weight of 43,800 lbs. (typical for 50-ton hoppers), your maximum gross weight would be 125,200 + 43,800 = 169,000 lbs. Track Scale Display Range limits are set to the nearest 10,000 lbs., so 170,000 lbs. would be the maximum programmed for this range.

For a minimum, coal hoppers will be filled to at least 95% of their nominal **capacity** – 95,000 lbs. for a 50-ton hopper. Add the **light weight** of 43,800 lbs: 95,000 + 43,800 = 138,800 lbs., which rounds up to 140,000 lbs. Thus 140,000 to 170,000 lbs. would be reasonable for this Display Range.

Similarly, you could define Display Ranges for other car types. Industry data shows that rail cars carry an average of about 60 to 70 percent of their rated **capacity**. This average includes the near-**capacity** loading of single commodity cars like coal hoppers, which brings the average up. So if you are defining a Display Range for a miscellaneous collection of loaded cars, center your range lighter than 60 to 70 percent of **capacity**, but feel free to keep minimum and maximum limits fairly wide.

Setting Display Ranges

Use the 3-Way Mode Switch in the center of the circuit board (see Figure 4) to set the three Display Ranges as follows:

1. Select the Range (A, B, or C) that you wish to set with the Display Range Selection Switch (see Figure 2).
2. The Mode Switch is normally kept in the **RUN** position.
3. Slide the Mode Switch to the **LO** position:
The Digital Display counts up from 0 in 10,000 lbs steps until user slides the Mode Switch to RUN.
4. When the desired weight is reached, slide the Mode Switch to **RUN**:
The last displayed weight will be **minimum** weight limit for this range. Low and high weight limits for this range are momentarily displayed to confirm the selection.
5. Slide the Mode Switch to the **HI** position:
After a short delay, the Digital Display counts down from 400,000 in 10,000 lbs steps until user sets Mode Switch to RUN.
6. When the desired weight is reached, slide the Mode Switch to **RUN**:
The last displayed weight will be **maximum** weight limit for this range. Low and high weight limits for this range are momentarily displayed to confirm the selection.
7. Repeat steps 1 through 6 to set the other ranges as desired.

Note: You cannot set a maximum weight limit lower than the current minimum weight limit, or a minimum weight limit higher than the current maximum weight limit. You may need to change one limit before the other to avoid this restriction.

Setting Sound Volume

Sound volume is controlled by the black jumper in the lower left corner of the circuit board (see Figure 4). Slip the jumper over the center and “L” terminals for a lower volume, or over the center and “H” terminals for a higher volume.

To turn off all sound, remove the jumper and slip it over just one of the gold pins for safe keeping.

Note: If the Bell option is off (as described in the next section), the Piezo Bell will not sound.

Selecting Typewriter, Bell & Data Link Options

Your **WeighStation™ Track Scale** has additional options that you can select in Settings Mode.

1. To enter Settings Mode, start with the 3-Way Mode Switch in the **RUN** position.
2. Slide the Mode Switch to the **HI** position and back to **RUN** three times, pausing about one second in each position.

Note: Pausing too long in either position will start setting the maximum weight limit for the current range (display counts down from 400,000) or put the scale into normal operation (display shows a “0”).

3. Your Track Scale is now in Settings Mode, beginning with the Typewriter Display setting as shown in Figure 5. Change the value to select either the Typewriter Display option (value = 1) or the Modern Display option (value = 0).



Figure 5: Typewriter Display Option. “tYPE.” is displayed with a 1 or 0 value. Setting the On/Off Switch to “Weigh” changes the value to 1 and turns on Typewriter Display option (top). Setting the switch to “Off” changes the value to 0 and turns off Typewriter Display Mode (bottom).

4. After you set the Typewriter Display option, slide the Mode Switch to the **HI** position and back to **RUN** one more time, pausing again for about one second between positions. This saves your Display option selection.
5. The Bell option is now displayed as in Figure 6. Change the value to turn the Bell on (value = 1) or off (value = 0).

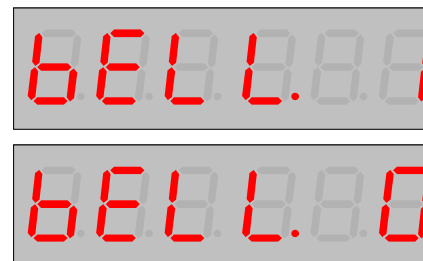

Figure 6: Turning Bell On/Off. “bELL.” is displayed with a 1 or 0 value. Setting the On/Off Switch to “Weigh” changes the value to 1 and turns on the Piezo Bell (top). Setting the switch to “Off” displays 0 and turns off the Bell (bottom).

- 6. After you have set the Bell option, slide the Mode Switch to the **HI** position and back to **RUN** one more time, pausing again for about one second between positions. This saves your Bell option selection.
- 7. The Reporting Data Link Speed option is now displayed as in Figure 7. Please see the **Report Data Link** section for a description of this feature. **If you are not using the Data Link, skip to Step 9 below.**



Figure 7: Reporting Data Link Speed Option. “dL.” is displayed with an “AVE”, “FAST”, or “SLO” value. Setting the On/Off Switch to “Off” sets the value to AVE, the typical speed for the Data Link (top). Changing the On/Off Switch to “Weigh” alternates the value between FAST (middle) and SLO (bottom) to slightly speed up or slow down the Data Link.

- 8. Set the value to AVE to run the Data Link at its normal speed. If needed to match the speed of connected equipment, change the value to speed up (value = FAST) or slow down (value = SLO) the Data Link.
For complete information on connecting to the Report Data Link, including link speed, please see the WeighStation Track Scale Data Link Application Guide at www.bouldercreekengineering.com/manuals.php.
- 9. After you have set the Reporting Data Link Speed option, slide the Mode Switch to the **HI** position and back to **RUN** one more time, pausing again for about one second between positions. This saves your Data Link Speed option selection. Your Track Scale will restart and return to normal operation.
- 10. Your Typewriter Display, Bell, and Reporting Data Link Speed settings are stored and used by your Track Scale until you change them again in Settings Mode.

Note: As noted above, you must successfully move on to the next option to permanently save your current selection. For example, your Bell option selection is only saved when you move on to the Data Link Speed option.

Report Data Link

Your **WeighStation™ Track Scale** has a Report Data Link output that transmits two different packets of information to the outside world:

- 1. After a completed weighing (after Step 6 in the **Operation** section above), the Track Scale transmits:

[W X nnnnnn] where X the current Display Range (A, B, or C), and nnnnnn is the 6-digit weight

For example, [W A 145600] if 145,600 is the weight on the “A” Range.

- 2. After the Display Range is changed, and also at power up, the Track Scale transmits:

[R X aaaaaa:bbbbbb] where X the new Display Range (A, B, or C), aaaaaa is the minimum weight in the Range, and bbbbbbb is the maximum weight in the Range

For example, [R B 060000:120000] if 60,000 lbs. is the minimum weight and 120,000 lbs. is the maximum weight on the “B” Range. (Notice that leading zeros are included to print six digits.)

The Report Data Link is designed to connect to a variety of external electronic and computer systems, including C/MRI, point-of-sale printers, and personal computers. Some systems can connect directly with the Data Link, and others require readily available connectors and cables.

Please see the WeighStation Track Scale Data Link Application Guide at www.bouldercreekengineering.com/manuals.php for complete information on connecting to the Report Data Link.

Support & Service

If you have problems with your **WeighStation™ Track Scale**, please consult our website www.bouldercreekengineering.com. If you need additional help, please contact us at support@bouldercreekengineering.com.

Your Track Scale can be repaired with a charge for parts and labor. Please contact support@bouldercreekengineering.com for a cost estimate on non-warranty repairs before sending product to us.

Limited Warranty

Boulder Creek Engineering, LLC warrants its products to be free of defects in materials and workmanship for a period of **one (1) year** from the purchase date. Defective product received by Boulder Creek Engineering during the warranty period will be repaired or replaced at our option. You must pay shipping to and from Boulder Creek Engineering.

This warranty does not cover damage resulting from negligent installation, improper operation, or unauthorized repair or modification. Removal of the heat shrink voids this warranty. Boulder Creek Engineering makes no other warranty of any kind, expressed or implied. In no event shall Boulder Creek Engineering be liable for incidental or consequential damages.

For warranty service, please contact Boulder Creek Engineering for a Return Merchandise Authorization (RMA) number. Product must be shipped to Boulder Creek Engineering with dated proof of purchase (your receipt).



2525 Arapahoe Ave.
Suite E4-605
Boulder, CO 80302

(303) 443-5784
support@bouldercreekengineering.com

Please visit www.bouldercreekengineering.com to see all of our Model Railroad products:

- **TrainBoss™** Talking Defect Detectors
- **WeighStation™** Track Scales
- **HotShot™** Speedometers
- **NightScope™** Infrared Detectors
- **BrassHat™** Announcers
- **BrassHat™** Recordable Sound Modules



(Photo courtesy of John Parker)